

# RETURN GOODS AUTHORIZATION REQUEST



DISTRIBUTORS: PLEASE COMPLETE FIELDS BELOW

<input type="text"/>	<input type="text"/>	<input type="text"/>
RGA# (Contact Flexpipe)	Today's Date	Approved By
<input type="text"/>	<input type="text"/>	<input type="text"/>
Your Name		Distributor Name
<input type="text"/>	<input type="text"/>	<input type="text"/>
Customer Name		Street Address
<input type="text"/>	<input type="text"/>	<input type="text"/>
City	State	Zip Code
<input type="text"/>	<input type="text"/>	<input type="text"/>
Flexpipe Invoice Number	Customer PO Number	Invoice Date

Disclaimer: Not filed within a year.....XXXX

**Please Note: To expedite your request, please complete and return this form with the goods.**

Complete and Return to Flexpipe. Check all boxes that apply to this return.

- Entire shipment is being returned. (Refused, duplicated, customer couldn't use)
- Flexpipe quality defect. (EXAMPLE: Billed for correct part no. but received wrong part no.)
- Damaged freight — replacement needed.
- Other: \_\_\_\_\_

Detailed explanation for return: \_\_\_\_\_

\_\_\_\_\_  
\_\_\_\_\_

Please attach packing slips and correspondence to this form. Write the RGA number on the packing slip AND shipping label

**FOR FLEXPIPE USE ONLY** (Complete after goods are received and checked)

<input type="text"/>	<input type="text"/>	<input type="text"/>
Received By	Date	Time AM PM
List returned materials in damaged or unusable condition. NON-RESTOCKING.		Additional Notes
<input type="text"/>	<input type="text"/>	<input type="text"/>
Credit Amount Issued (If applicable)	QC Inspection By	Date
<input type="text"/>	<input type="text"/>	<input type="text"/>
Credit/Billing Authorization		Date



Revised 01-06-2024

Credit/Billing Authorization

Date

# RETURN GOODS AUTHORIZATION REQUEST

Follow these guidelines to ensure that the product is returned in good condition for maximum credit.

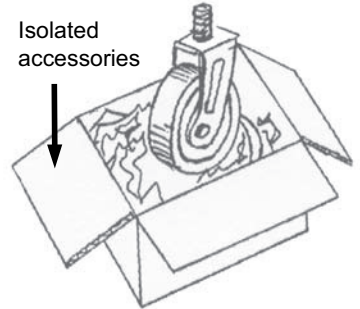
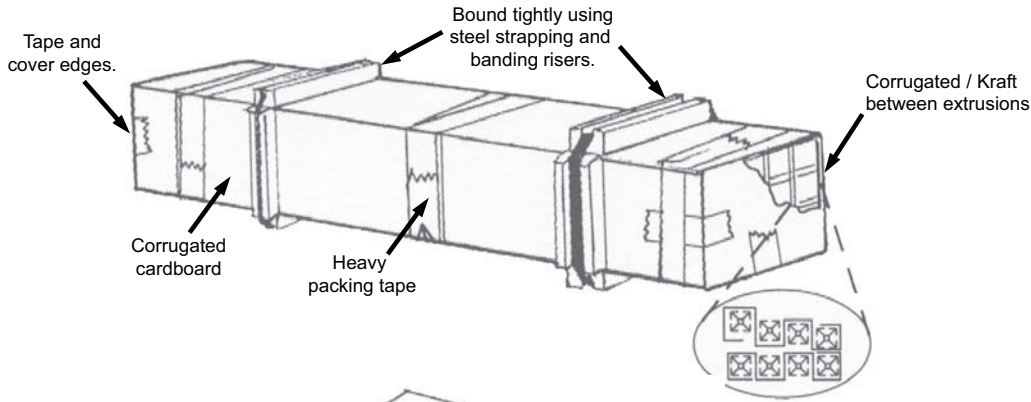

Stretch or paper wrap and tape bound accessories  
4 lbs. max

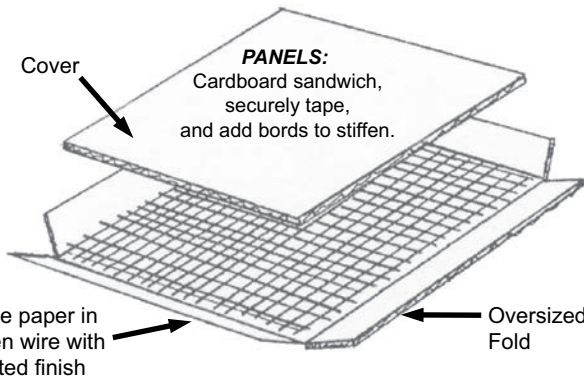
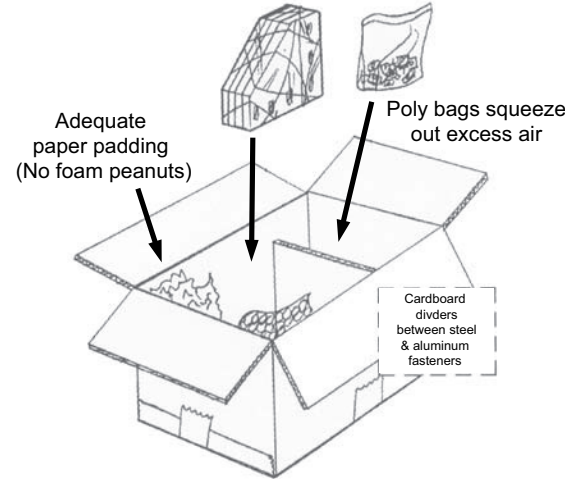

**NOTE:** Plastic panels cannot be returned once protective wrap is removed

## IMPORTANT:

- Avoid any metal to metal contact, or wrap tightly.
- Do not use any adhesive tape against metal parts-wrap with paper first.
- Avoid internal bundles over 4 lbs.
- When in doubt, over wrap it, or call (855) 406-0253.

Material	Packaging	Internal Cushion	Internal Divider
Cardboard (Corrugated)	Yes	Yes	Yes
Stretch Wrap (Polyethylene)	No	Yes (As Binder)	Yes (As Bundle Material)
Bubble Wrap	No	Yes	Yes
Foam Peanuts	N/A	No	No
Packing Tape	Yes	No	Yes (Only Over Kraft Paper)
Newsprint Paper	No	Yes (Crumpled)	Yes (Taped Bundles, Crumpled)
Stretch Wrap	No	Yes (Between Profiles)	Yes